



DATA SHEET
table-cell - 1 x 1

„Automating the future together“



table-cell - 1 x 1

- Various combinable cell modules that enable a wide range of combinations thanks to a grid dimension of just 50 mm
- Thanks to the ergonomic height of the table, the cell can also be used for semi-automated processes
- Cable routing options in the cell components allow flexible supply to all consumers
- Switch cabinet, pneumatic distribution etc. are located in the lower part of the cell
- Good view of the process through large viewing windows
- Sturdy frame construction allows in-house transportation by forklift or transport crane
- Can be used as a stand-alone unit or in a system network

OPTIONS

- Switch for requesting and acknowledging doors directly on each door
- Lighting modules for better illumination in the cell
- For downstream processes, the solenoid interlock is converted to mechanical guard locking
- Cell roof and color filter on the side, e.g. to block out extraneous light during visual processes
- Cable guide pillars for laying large quantities of cables upwards

- ① Doors
- ② Base frame
- ③ Table top
- ④ Switch cabinet
- ⑤ Filling
- ⑥ Light grid

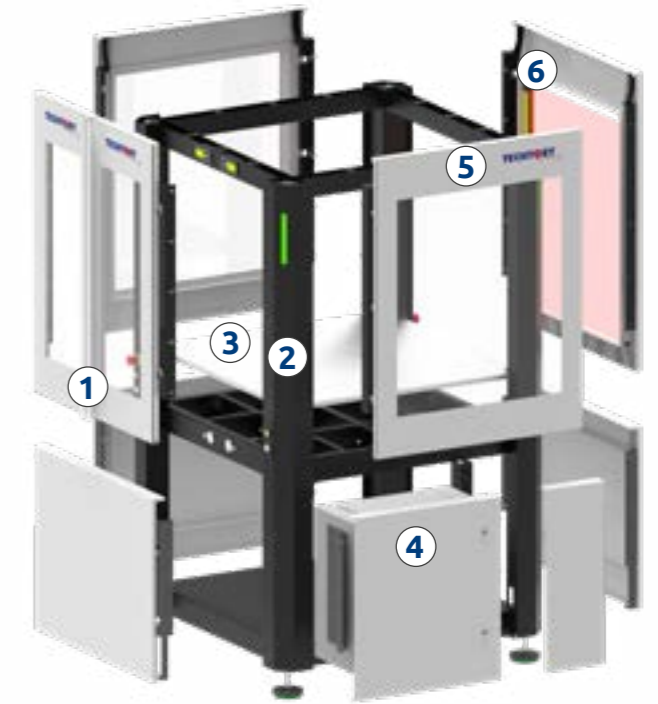

TECHNICAL PROPERTIES

Length (A)	1.218 mm	Usable length (A1)	950 mm
Width (B)	1.190 mm	Usable width (B1)	950 mm
Height (C)	2.052 mm	Table height (C1)	950 mm
Weight	459 kg		

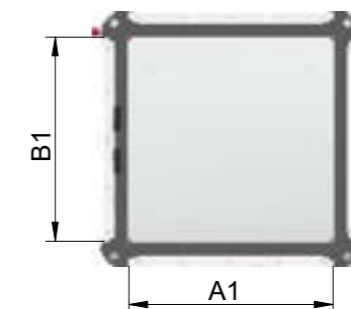
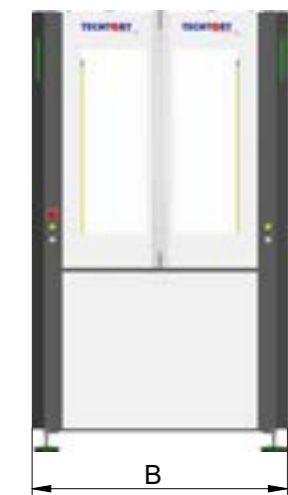
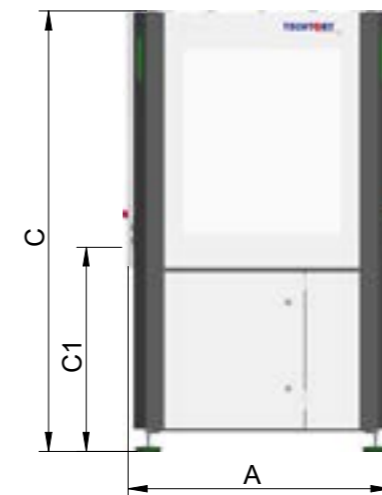



TECHTORY GmbH
Automation and
machining technology

Ludwig-Winter-Straße 5
77767 Appenweier
+49 7805 9589-0
info@techtory.de